



Underground Motor Grader

BG 110-M Mining

Underground Motor Grader

BG 110-M (4 x 4)

Optional: Front dozer blade or compactor



The BG 110-M was developed in collaboration with mining specialists especially for use in mining applications. With a height of only 1.80 m and an overall length without attachments of less than 7.40 m, it can be operated in even the smallest of mines in the world.

Thanks to the hydrostatic all-wheel drive, the driver can alternate the speed at will in that gear. A high starting torque ensures maximum thrust even at low speeds and motor

revolution speeds. The 2-gear transmission in use enables the grader to move at a maximum speed of 33 km/h.

The open canopy design with its readily accessible controls provides excellent ergonomic working conditions for the operator and eliminates driver fatigue. The electrical equipment boasts a very high degree of protection for work underground. Several soot particle filters are available as optional

accessories for the grader to ensure compliance with the strict environmental requirements in mining.

The load-sensing hydraulic system in the BG 110-M supplies the loads only as required and affords a flow control independent of the load. This allows the control valves of the working hydraulics to be actuated simultaneously or independent of one another.

The BG 110-M is based on decades of HBM experience in the



Open canopy – FOPS-approved, electrical equipment with protection class IP65

Hydraulic articulated steering $\pm 30^\circ$

Cyclone filter for use in sandy and dusty environments

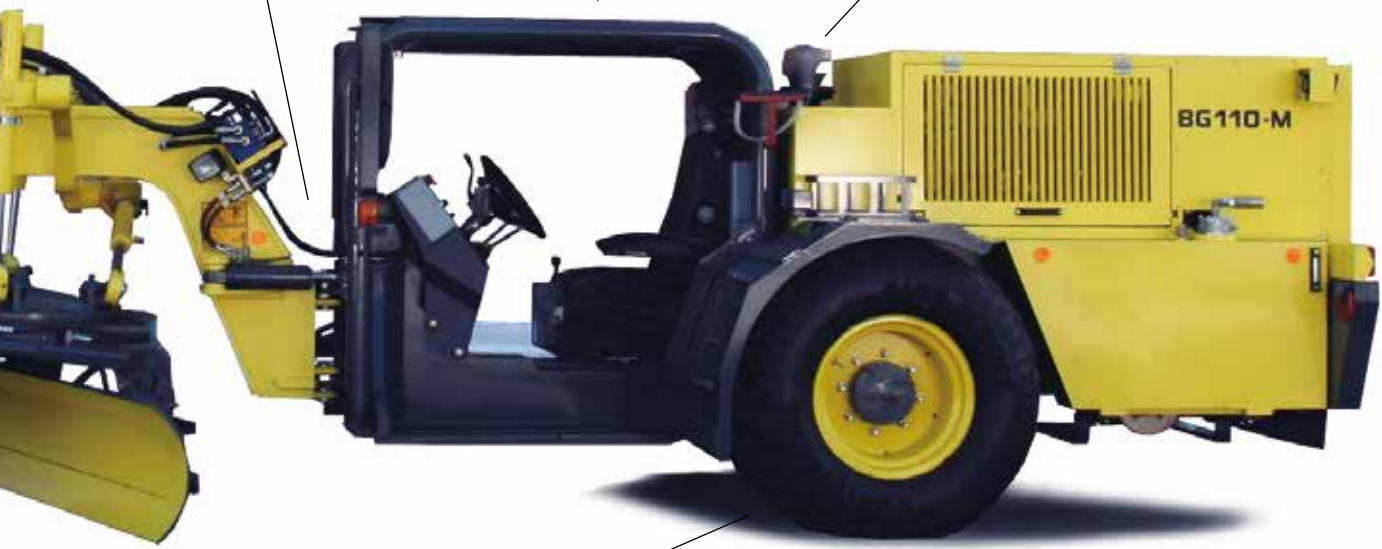

Hydrostatic all-wheel drive

Maximum machine height 1.80 m



field of grader construction, and offers the user an instrument for mining maintenance-of-way applications both above and below ground and especially in tight conditions – a real mining expert.



Engine Data

Make/Model	Perkins/Diesel engine 1104D-E44TA
Type	4-cycle, direct injection, turbocharged, intercooled
Rated horsepower (ISO14396)	at 2200 rpm 97KW / 132 PS
Number of cylinders, type	in line 4
Bore and stroke	105 x 127 mm
Displacement	4.4 litres

The engine is equipped with a dual element, dry-type air filter with dust ejector. 24 volt starting and electrical system, 75 amp alternator.



Operating Weight

Total weight	approx. 8600 kg
On rear wheels	approx. 6500 kg
On front wheels	approx. 2100 kg



Drive System

Hydrostatic all-wheel drive system for front and rear axle. Drive in energy-saving closed circuit. Due to flow divider in the first drive position, it is possible to drive front and rear axle in a locked manner. The speed of each drive position can be controlled infinitely variable.



Speeds

Forward	km/h
1st gear (flow divider)	4.0
2nd gear	15.0
3rd gear	33.0

Reverse
Reverse speed same as forward speed.
Acoustic back-up alarm in reverse driving.



Front and Rear Axle

Make: DANA

Front axle as steering/swinging axle type 212 with Rexroth A6VM107 hydraulic engine.

Rear axle type 112 with two 2-speed manual gearbox type 357 (shiftable at standstill) with Rexroth A6VM107 hydraulic engine.

45 % No-Spin differential.



Wheels & Tyres

Tyre size	Continental 22-20 E7 Grip (560/50 - 20) diagonal
Rim size	17 x 20
	Other tyres on request.



Brakes

Service brake

Dual-circuit braking system on front / rear axle. Wet multi-disc oil-bath types, effective on all four wheels. Includes reserve power and operator warning system.

Parking brake

Acts independently upon the rear axle, spring-loaded brake, electrically actuated.



Frame

Front and rear frame sections are connected with an adjustment free articulation joint.

Front: fully welded box section,

Dimensions 240 x 240 mm

Rear: fully welded frame structure
(solid main bars)

560 x 60 mm

Hydraulic articulated frame steering (right/left) ±30°



Drawbar

Fully welded, compact, A-shaped construction.

Dimensions (solid sections) 30 x 170 mm



Circle

Hardened teeth, machine-cut on inside of circle for maximum strength and minimum wear.

The circle is held positively in place at four points by four clamps and guide shoes. The clamp and guide shoes are located where the greatest force is exerted. Plastic anti-wear inserts ensure high wear resistance and easy servicing.

Diameter of circle 1200 mm

Thickness 35 mm

Height 95 mm

Adjustable guides 4



Circle Drive

Hydraulically driven worm gear transmission. Circle drive system fully protected against impact damage by an overload clutch.



Moldboard (Standard)

Moldboard (10 ft) 3050 x 505 x 15 mm (10' x 19,9" x 0,6")

Blade material fine grained steel

Blade pull (at a friction factor of 0.8) 68.8 kN



Blade Range

Reach outside tyres without articulation (RH&LH), blade resting on levelled surface	1100/880 mm
Reach outside tyres with articulation (RH&LH), blade resting on levelled surface	1680/1460 mm
Blade side shift	1000 mm
Blade tilt range	83°-57°
Lift above ground	300 mm
Cut below ground	200 mm
Distance blade/front axle	1811 mm

All blade movements and positions can be controlled from the operator's seat.



Steering

Fully hydraulic steering with emergency steering.	
Turning radius without articulation	8200 mm
Turning radius with articulation	5700 mm
Steering angle	45°



Load-Sensing Hydraulics

The control valves of the working hydraulics can be actuated simultaneously and independent of each other. The load-sensing pump (axial piston pump) discharges only the required quantity of oil if a control valve is actuated. When hydraulic power is not required system pressure is only 24 bar and this low standby pressure improves fuel efficiency.

Cylinder drifting is prevented via lock valves and brake valves complete with emergency lowering.

Operating pressure	184 bar
Max. oil flow	99 l/min



Canopy (open operator's station) - FOPS -approved

Operator's station with excellent ergonomic features for the driver. Readily accessible controls for fatigue-free operation. The electrical equipment has the IP65 protection class of.

Dimensions	
Width	1406 mm
Depth	1424 mm
Height (floor plate/roof)	

Can be equipped with an array of accessories (see optional equipment).



Capacities

Fuel	120.0 litres
Hydraulic oil	190.0 litres
Engine oil	12.0 litres
Front axle	9.8 litres
Rear axle	11.0 litres
Circle drive	6.0 litres
Coolant	40.0 litres



Light Equipment

2 head lights at the front, every 2 indicator lights (including hazard warning lights) at the front and rear as well as at the operator's station, 2 rear lights, 2 brake lights, 1 backup light plus every 2 working lights at the top of canopy and at the bottom of front frame.



Optional Equipment

Basic machine with higher placed operator's station

Overall height of machine	2500 mm
Height seat to ground	1300 mm (standard version 870 mm)
Ground clearance rear axle (driver's position)	391 mm

Beacon (orange)

Cooling box

Prearrangement for installation of Radio / wireless transmitting set (CB radio)

Protective grids for lights

Mudguards on front wheels

Front dozer blade with position indicator, parallel guided

Width/Height	2490 x 765 mm
Cut below ground	130 mm
Lift above ground	585 mm
Weight	410 kg

Scarifier in front of front axle (11 teeth)

Ripping width	1400 mm
Ripping depth	215 mm
Lift above ground	290 mm
Weight	610 kg

Triple-plate compactor

Compacting width	2600 mm
Centrifugal force	3 x 60 kN
Weight	1400 kg

Connected with basic machine by means of an hydraulically adjustable hitching attachment.

Mechanically adjustable blade angle.

Transversal inclination compensation ± 7°

Floating position electrically switchable.

Overall weight of triple-plate compactor and hydraulic coupling 2000 kg

Moldboard (11 ft) 3355 x 505 x 15 mm (11' x 19,9" x 0,6")

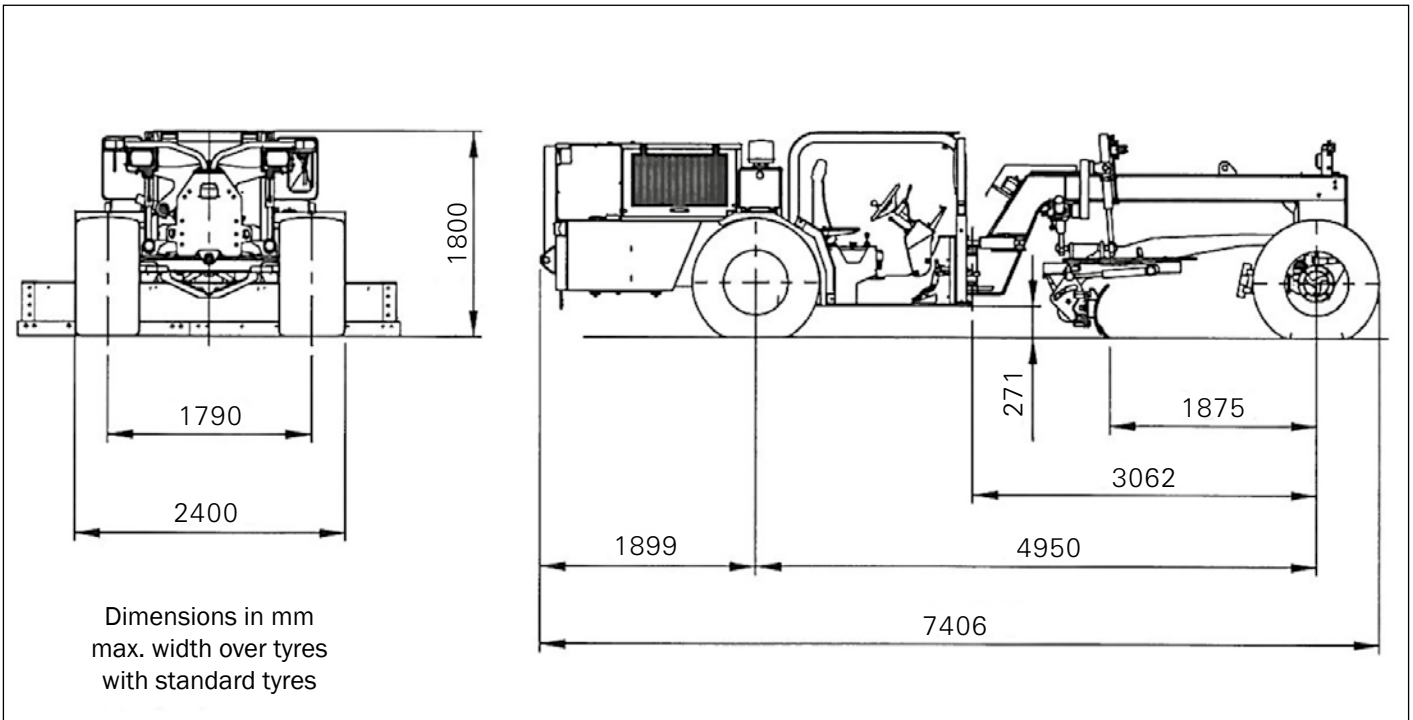

Cover plate for upper guide rail of moldboard

Adjustable moldboard corner shoes, left or right

Float position for both moldboard lift cylinders

Wheels and tyres – on request

Protective cover for muffler

Articulation angle indicator

Special paint

Diesel particulate filter (DPF) - CWF

PTL monitoring

Automatic idle running

Diesel particulate filter (DPF) - SMF

with additive addition and electronic monitoring

Tool kit, wheel chocks, warning triangle, fire extinguisher, first aid kit

CE certificate

Speed limitation at 15 km/h possible

